

402-VLZ3

The 402-VLZ3 is an ultra-compact model in the VLZ3 line of compact mixers, specially designed for applications that require fewer inputs but demand professional sound.

The 402-VLZ3 is equipped with two mono mic/line channels and one stereo line-input channel, for a total of four input channels. The mic/line channels feature Mackie's XDR2 mic preamps, which deliver pure, clean, studio-grade sound with an incredibly wide frequency range, especially in the low end, and even at extremely high gain settings. They offer incredibly low noise, amazing RFI rejection, and 60dB of available gain per channel.

Each mic/line channel also has phantom power, an input Gain control, a Hi-Z instrument switch, a sharp 18 dB/octave, 100 Hz Low Cut filter, 2-band EQ, stereo pan switch and a Level control. The stereo line-input channel simply has a Level control.

There is a stereo tape input with its own input Level control, and a stereo tape output for recording.

Other features include a 1/4-inch stereo headphone jack with Level control, stereo 8-segment LED meters and TRS stereo output jacks.

The 402-VLZ3 is the best sounding, most professional ultra-compact mixer in its class. Thanks to its versatile, professional design, you can now get exceptional sound quality and performance in an amazingly small footprint.

APPLICATIONS

Live sound mixing, houses of worship, clubs, gymnasiums, banquet halls, conference rooms, boardrooms, studio and field recording, multimedia applications, broadcast, and many, many more.



FEATURES:

- Ultra-compact 4-channel mixer featuring Mackie VLZ3's signature low noise, high-headroom design
- 2 studio-grade XDR2™ Extended Dynamic Range mic preamps with:
 - Ultra-wide 60 dB gain range
 - 130 dB dynamic range
 - +22 dBu line input handling
 - Extended low-frequency response
 - Distortion under 0.0007% (20 Hz - 20 kHz)
 - Phantom power for studio condenser mics
- Four high-headroom line inputs
- Two selectable DI inputs
- 2-band active EQ (80 Hz, 12 kHz)
- 18 dB/octave, 100 Hz low-cut filter on mic input channels
- Dedicated Stereo Line Input and Tape Input channels
- High-resolution 8-segment stereo meters
- Sealed rotary controls to resist dust and grime
- Includes Tracktion 3 Basic Bundle for Mac/PC (download required)

402-VLZ3 SPECIFICATIONS

Main Mix Noise

(20 Hz to 20 kHz bandwidth, 1/4" Main Out, channels 1-2 Gain @ unity gain, channel EQs flat, Stereo Pan button in)

Main Mix knob down, channel Level knobs down	-103 dBu
Main Mix knob @ unity, channel Level knobs down	-98 dBu
Main Mix knob @ unity, channel Level knobs @ unity	-92 dBu
Signal-to-Noise Ratio, ref. +4 dBu	102 dB

Total Harmonic Distortion (THD)

(1 kHz @ 35 dB gain)

20 Hz to 80 kHz bandwidth	<0.005%
20 Hz to 20 kHz bandwidth	<0.003%

Attenuation / Crosstalk

(1 kHz relative to 0 dBu, 20 Hz to 20 kHz bandwidth, Line In, 1/4" Main Out, Gain @ unity)

Main Mix knob down	-70 dBu
Channel Level knob down	-94 dBu

Frequency Response

(Mic In to any output)

20 Hz to 50 kHz	+0 dB / -1 dB
20 Hz to 90 kHz	+0 dB / -3 dB

Equivalent Input Noise (EIN)

(Mic In to Main Out, max gain)

150 Ω termination, 20 Hz to 20 kHz bandwidth	-129.5 dBu
---	------------

Common Mode Rejection Ratio (CMRR)

Mic In, max gain @ 1 kHz	better than -70 dB
--------------------------	--------------------

Maximum Levels

Mic In	+21 dBu
Tape In	+24 dBu
All other inputs	+22 dBu
All outputs	+22 dBu

Impedances

Mic In	3.4 k Ω
All other inputs	10 k Ω or greater
Tape Out	1.0 k Ω
Phones Out	60 Ω
All other outputs	120 Ω

EQ

High Shelving	± 15 dB @ 12 kHz
Low Shelving	± 15 dB @ 80 Hz

AC Power Requirements

Power Consumption	8 watts
US, JP	100 - 120 VAC, 50 - 60 Hz
EU, UK, AU, CN	200 - 240 VAC, 50 - 60 Hz
External Power Supply AC Connector	2-pin IEC 250 VAC
Operating Temperature	0° - 40°C 32° - 104°F

External Power Supply

US Adapter (18.5 VAC x 2, 350 mA, US)	P/N 0028090-00
EU Adapter (18.5 VAC x 2, 350 mA, EU)	P/N 0028090-01
JP Adapter (18.5 VAC x 2, 350 mA, JP)	P/N 0028090-02
UK Adapter (18.5 VAC x 2, 350 mA, UK)	P/N 0028090-03
AU Adapter (18.5 VAC x 2, 350 mA, AU)	P/N 0028090-04
CN Adapter (18.5 VAC x 2, 350 mA, CN)	P/N 0028090-05

Physical Properties (packaged product)

Height	12.5 in / 318 mm
Width	8.8 in / 222 mm
Depth	4.3 in / 108 mm
Shipping Weight	3.8 lb / 1.7 kg

Physical Properties (product)

Height	7.3 in / 186 mm
Width	5.8 in / 147 mm
Depth	1.6 in / 41 mm
Net Weight (without power supply)	2.5 lb / 1.1 kg
Net Weight (with power supply)	3.0 lb / 1.4 kg

Ordering Information

402-VLZ3 4-Ch. Compact Recording/SR Mixer, US	P/N 0027489-00
402-VLZ3 4-Ch. Compact Recording/SR Mixer, EU	P/N 0027489-01
402-VLZ3 4-Ch. Compact Recording/SR Mixer, JP	P/N 0027489-02
402-VLZ3 4-Ch. Compact Recording/SR Mixer, UK	P/N 0027489-03
402-VLZ3 4-Ch. Compact Recording/SR Mixer, AU	P/N 0027489-04
402-VLZ3 4-Ch. Compact Recording/SR Mixer, CN	P/N 0027489-05

402-VLZ3 DIMENSIONS

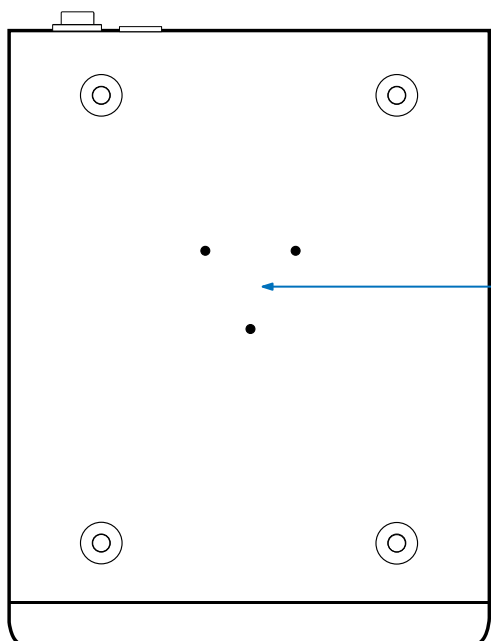
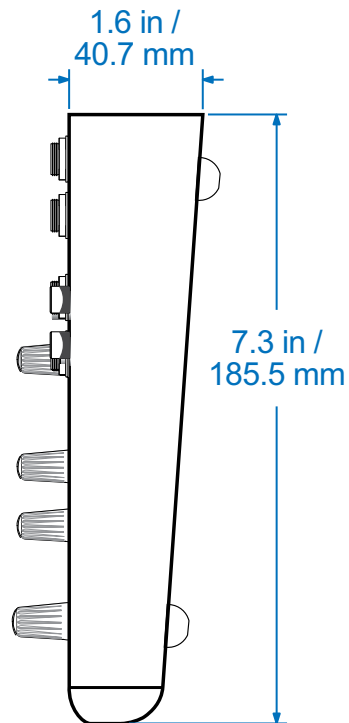
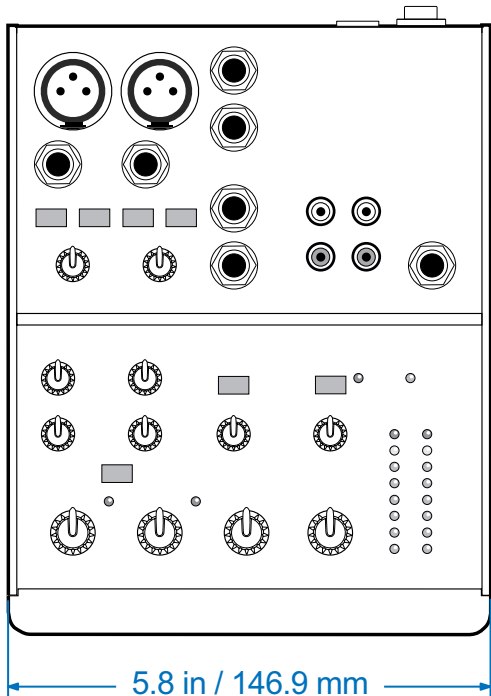
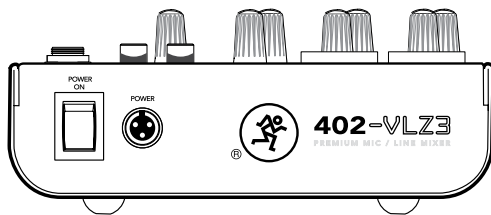

Holes for microphone stand adapter

MICROPHONE STAND

The bottom panel of the 402-VLZ3 has three non-threaded holes that allow it to be fitted with an optional microphone stand adapter. This lets you support the mixer on a standard mic stand, and adjust its height and level to whatever suits your preferences.

The Atlas AD-11B mic stand adapter is available at many music stores. It is made and distributed by Atlas Sound.

Use three self-tapping machine screws 6-32 x 1/4" long to secure the adapter to the bottom of the 402-VLZ3.

Do not use screws longer than 1/4" as these could damage the circuit boards. Do not use screws shorter than 1/4", or the adapter will not be securely fixed to the mixer.

402-VLZ3 BLOCK DIAGRAM

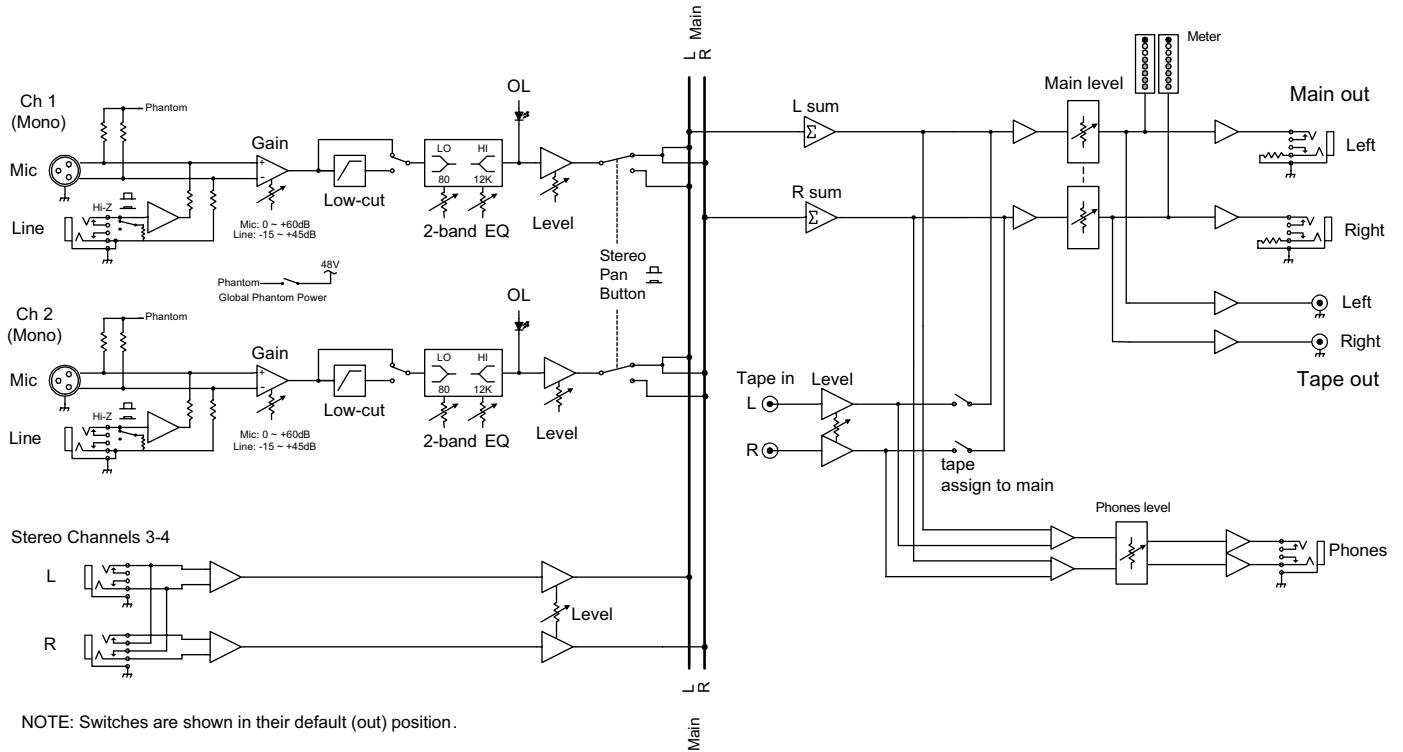

MACKIE®

402-VLZ3

PROFESSIONAL ULTRA-COMPACT MIXER

402-VLZ3 FRONT AND REAR PANELS

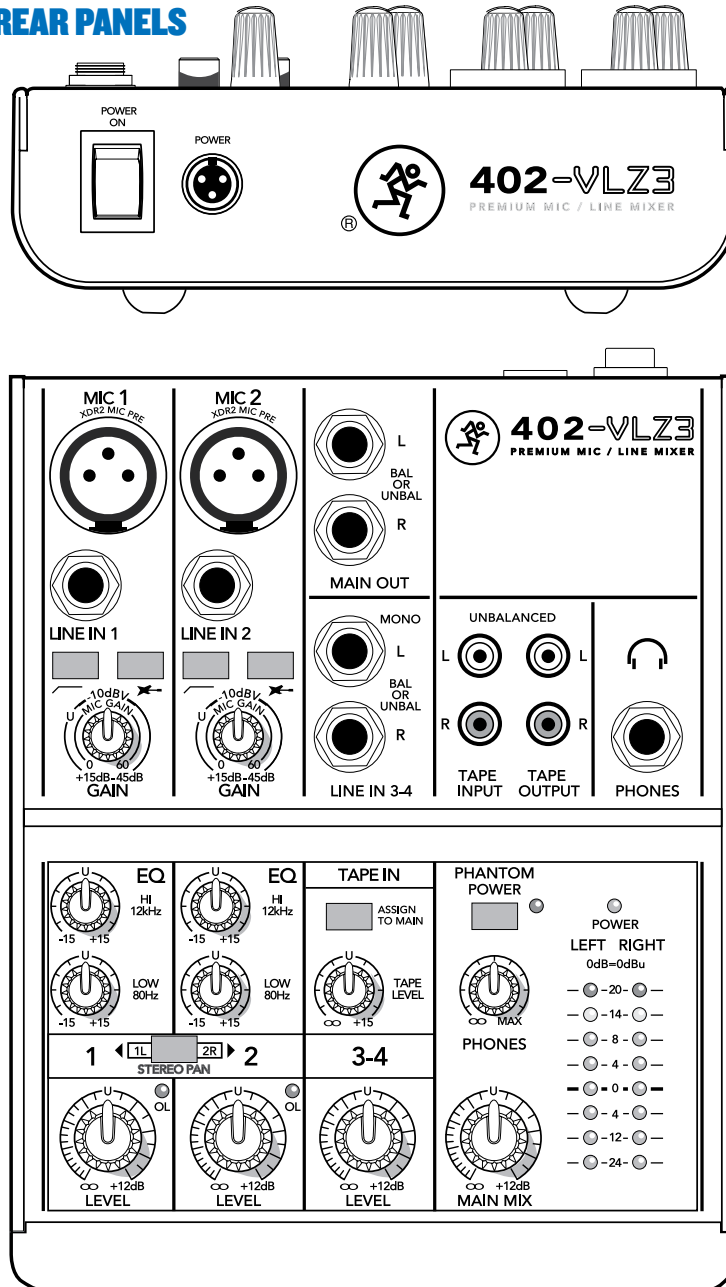

Electronic files for this product are available at:

www.mackie.com

Specification Sheet

402VLZ3_SS.PDF

Owner's Manual

402VLZ3_OM.PDF

MACKIE®

www.mackie.com

16220 Wood-Red Road NE

Woodinville, WA 98072 USA

800-898-3211, Fax 425-487-4337, sales@mackie.com

Since we are always striving to make our products better by incorporating new and improved materials, components, and manufacturing methods, we reserve the right to change these specifications at any time without notice. "Mackie" and the "Running Man" figure are registered trademarks of LOUD Technologies Inc. All other brand names mentioned are trademarks or registered trademarks of their respective holders, and are hereby acknowledged.

Part No. SW0769 Rev. B 12/10

©2010 LOUD Technologies Inc. All Rights Reserved.